

Fuel Pump Driver Module (FPDM)

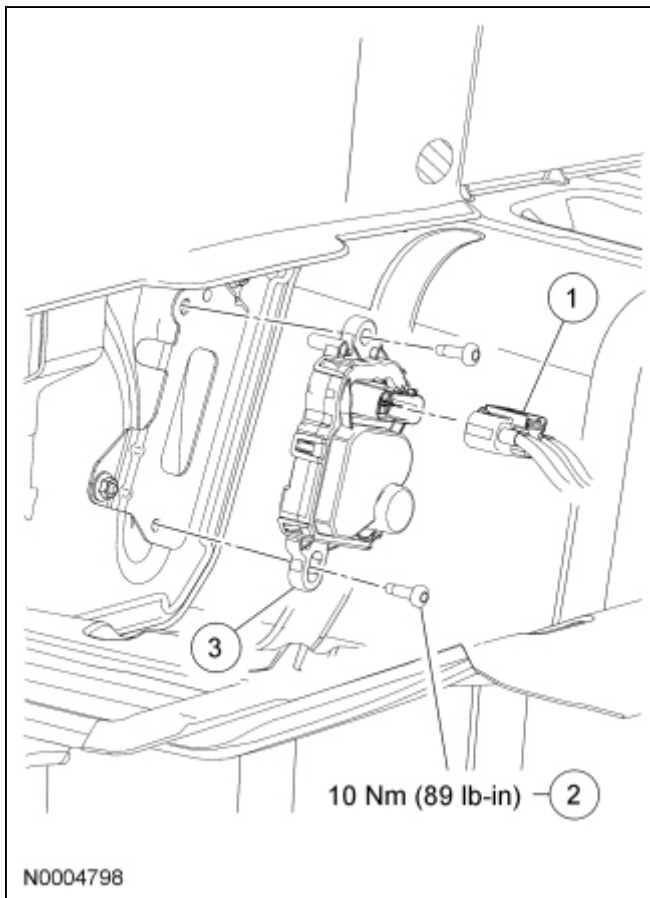

Item	Part Number	Description
1	14A464	Fuel Pump Driver Module (FPDM) electrical connector (part of 14A005)
2	W504755	FPDM bolt (2 required)
3	9D370	FPDM

Removal and Installation

NOTE: The Fuel Pump Driver Module (FPDM) is located in the spare tire stowage compartment.

1. Disconnect the [FPDM](#) electrical connector.
2. Remove the 2 bolts and the [FPDM](#).
 - To install, tighten to 10 Nm (89 lb-in).
3. To install, reverse the removal procedure.

